

SWING GATE OPENER

SWARM600



GATEWAY TO CONVENIENCE AND SAFETY !!!



MODEL:SWARM600



TECHNICAL CHARACTERISTICS

Motor	24V DC
Gear type	Worm gear
Max. absorbed power	144 W
Peak thrust	3500 N
Max. operating current	5.5 A for maximum 10 sec
Nominal thrust	3500 N
Max. gate weight	300 kg per leaf
Max. gate length	3 metres



DIMENSIONS

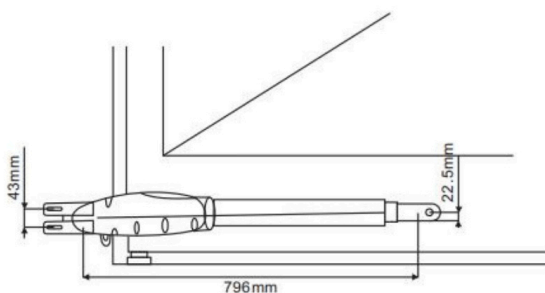



INTELLIGENT FEATURES

- The double gate opening system is a robust, tuff, long lasting and a quite opening and closing system for double swing gates upto 4 mtr in length.
- Applicable for residential and commercial purpose.
- Remote range is upto 50 Meters from the gate.
- Motor is designed as an Articulated motor with high pressure casting Body with fibre housing.
- Slow down its operation during the opening and closing phase.
- Worm gear provides durability and silence in motor operation.
- The motor is fitted with an emergency manual override on each motor to allow the user to open the gates manually in case of an emergency such as a power failure situation.
- The motor can handle both light and heavy gates.
- The two motors make up a durable and powerful DC unit and the gear box is heavy duty and all years are constructed of metal (no plastic, fibre or nylon)
- Can add any optional devices.
- The motor kit provides complete accessories and materials for easy installation.



WIRING DIAGRAM

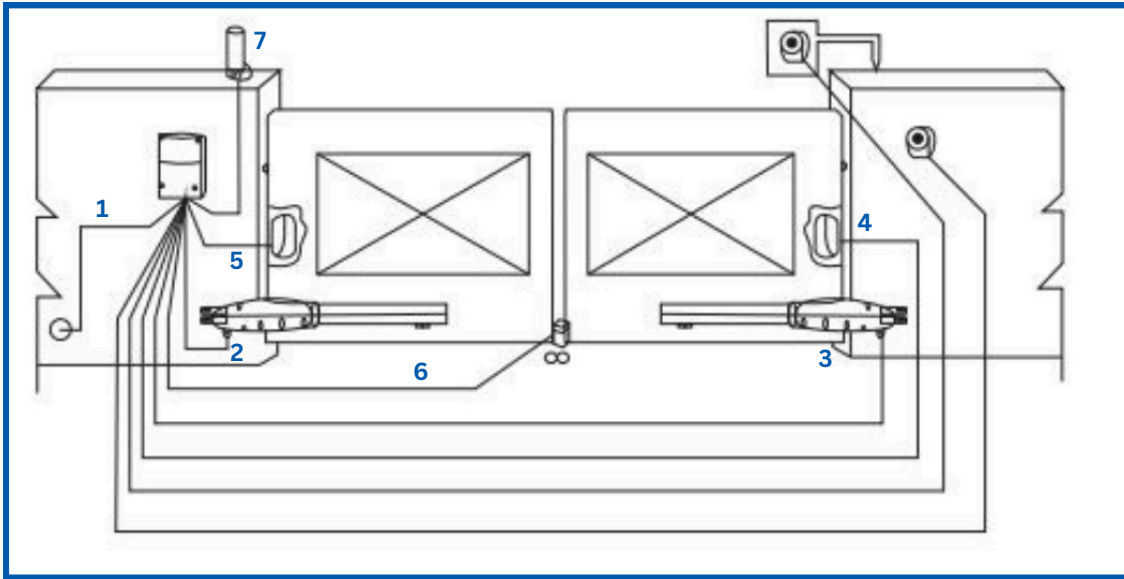

- 1: Power Cable [P N E]
(Guage depends on distance)
- 2: 2 core 1 sq cable - 1st motor
- 3: 2 core 1 sq cable - 2nd motor
- 4: Cat6 Cable- safety sensor
- 5: Cat6 Cable- safety sensor
- 6: 2 core 1 sq cable- lock
- 7: Cat6 cable- Flash light

OPTIONAL DEVICES



WIFI MODULE



PHOTOCELL

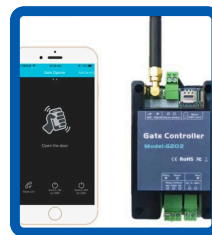

GSM



LOOP DETECTOR



FLASH LIGHT



UHF READER

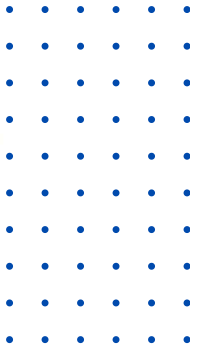

OPEN YOUR WAY TO THE ULTIMATE

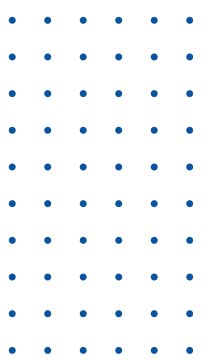

SAFETY MATTERS
www.siwstech.com